

Overview

The AXR-IRSM+ (FIG. 1) is a remote IR receiver for use with both AMX Axxess/NetLinx Central Controllers and operates via the AXlink bus to remotely control AXlink devices. The AXR-IRSM+ is in a swivel-mount enclosure for wall or ceiling installations. The AXR-IRSM+ (FG454-01) works with AMX 38 kHz or 455 kHz IR transmitters.

Note: The AXD-IR+ wallmount version is also available for US-style single-gang enclosure installations.

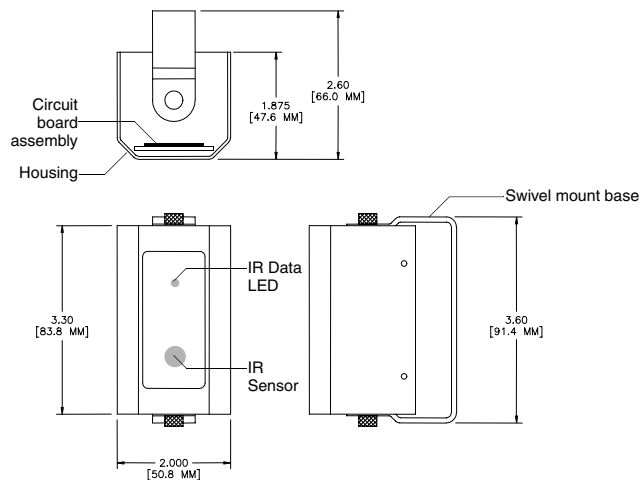

FIG. 1 AXR-IRSM+ swivel-mount IR receiver

AXR-IRSM+ Specifications	
Dimensions (HWD):	3.30" x 2.00" x 2.6" (83.80 mm x 50.80 mm x 66.00 mm)
Receive Frequencies:	38 / 455 kHz (user-selectable)
Enclosure	Neutral off-white metal enclosure (FG454-01)
Mounting:	May be used without the wall bracket for flush mounting. Comes with full set of mounting screws and wall anchors.
Weight:	5.6 oz (174 grams)
Power Consumption:	35 mA

Wiring and Installation

Set the receive frequency, AXlink device number and IR validation level before installing the AXR-IRSM+. To access the jumper pins or switches on the circuit board assembly, separate the housing from the swivel base, as shown in FIG. 1.

FIG. 2 illustrates the location of key components on the AXR-IRSM+ circuit board.

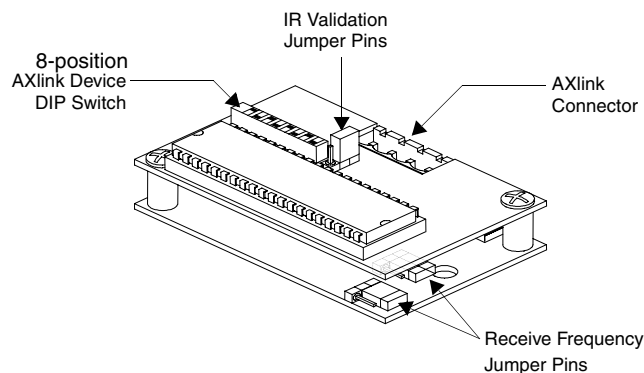

FIG. 2 Location of key components on the AXR-IRSM+ circuit board

Setting the Receive Frequency

Use the set of jumper pins on the corner of the circuit board to set the receive frequency. FIG. 3 illustrates the configuration of the jumpers.

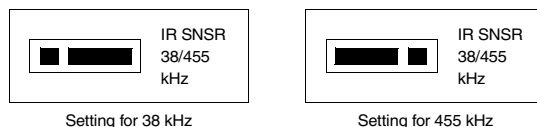

FIG. 3 Receive frequency jumper settings

Note: The unit will not operate with one set of pins configured for 38 kHz and the other set of pins configured for 455 kHz.

- To receive 455 kHz (default setting), position both jumpers on pins 1 and 2 (away from the edge of the circuit boards).
- To receive 38 kHz, position both jumpers on pins 2 and 3 (near the edge of the circuit boards).

Setting the AXlink Device Number

- Locate the 8-position Device DIP switch (FIG. 2).
- Set the device address according to the DIP switch values shown below.

Switch	1	2	3	4	5	6	7	8
Value	1	2	4	8	16	32	64	128

The device number is set by the total value of DIP switch positions that are ON (down). The Axxess software program in your system typically uses device numbers 128 through 255 for the panels.

As an example, the DIP switch in FIG. 4 defines device number 129 (1+128=129).

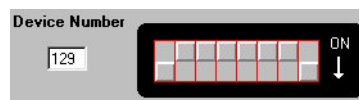

FIG. 4 Example Device DIP Switch set to 129

Note: If you later change the device number, remove and reconnect the AXlink connector to enter the new device number into memory.

Sensor IR Validation Level

The IR validation level is set on the receiving device (such as an AXC-RCVI).

Setting the IR Validation Level

An IR transmitter must send repetitions of data for the receiver to accept it as valid data. In some installations, a light wall color or other physical condition may interfere with the sensor's or receiver's ability to sense the transmitted signal. The signal may reflect or bounce and become distorted. The receivers can be set to use either two or three repetitions of sequential signals to validate and accept the signal data.

Perform the following steps to set the receiver's IR validation level.

- Locate the IR Validation jumper pins (J1) (FIG. 5) on the circuit board (FIG. 2).

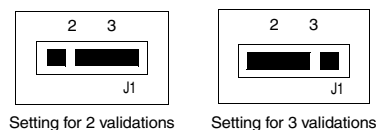

FIG. 5 IR validation jumper pin settings

- Position the IR validation jumper (FIG. 5) to select the number of valid IR data repetitions to be accepted:
 - Position the jumper at 2 to have the unit validate 2 sequential signals.
 - Position the jumper at 3 to have the unit validate 3 sequential signals.

Wiring the IR Sensors and Receivers

The AXR-IRSM+ uses a 4-pin AXlink connector for power and data. If the distance between the sensor and Central Controller exceeds power

consumption limits, you can connect a local 12 VDC power supply to the AXlink connector.

Preparing Captive Wires

You will need a wire stripper and a flat-blade screwdriver to prepare the captive wires:

1. Strip 0.25 inch (6.35 mm) of wire insulation off all wires.
2. Insert each wire into the appropriate opening on the connector according to the wiring diagrams in this section.
3. Turn the flat-head screws clockwise to secure the wire in the connector.

Note: Do not over-torque the screw. Doing so can bend the seating pin.

Wiring Guidelines

The AXR-IRSM+ requires 12 VDC power to operate properly. The power is supplied by the AMX system's AXlink cable. The maximum wiring distance between the Central Controller and the receiver is determined by power consumption, supplied voltage, and the wire gauge used for the cable. The following table lists wire sizes and the maximum lengths allowable between the receiver and the Central Controller. The maximum wiring lengths are based on a minimum of 13.5 volts available at the Central Controller's power supply.

Wiring Specifications @ 35 mA	
Maximum Wiring Length	
Wire Size	Distance
18 AWG	3000 feet (914.40 m)
20 AWG	2121.64 feet (646.68 m)
22 AWG	1,322.75 feet (403.17 m)
24 AWG	833.80 feet (254.14 m)

If you install the unit farther from the Central Controller than recommended in this table, connect an external 12 VDC power supply, as shown in FIG. 7.

Connection and Wiring

Wiring the AXR-IRSM+ AXlink

Install the AXlink data/power bus wiring as shown in FIG. 6.

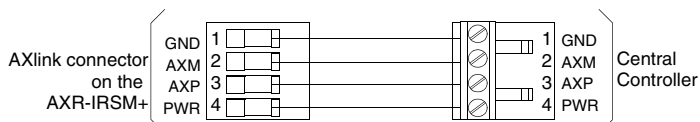

FIG. 6 AXlink wiring

Using the AXlink connector with an external 12 VDC power supply

Use a 12 VDC power supply when the distance between the Central Controller and the sensors or receivers exceeds the limits described in the Wiring Specifications table above. Make sure to connect only the GND wire on the AXlink connector when using a 12 VDC power supply (FIG. 7).

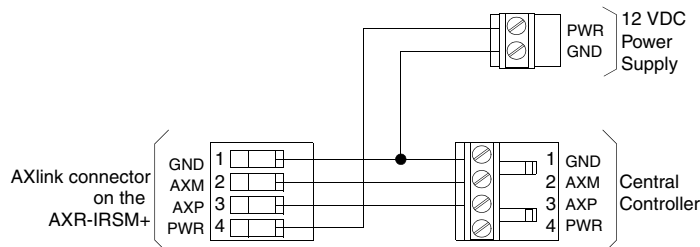

FIG. 7 AXlink wiring with an external 12 VDC power supply

Note: Do not connect the PWR wire to the AXlink connector's PWR (+) terminal on the Central Controller's side.

Checking IR Data Status

Locate the red IR Data LED on the front of the unit (FIG. 1). Point the system's AMX transmitter towards the sensor and press a button. The IR Data LED lights when the unit receives data.

If the IR Data LED does not light:

- Verify that the transmit LED on the transmitter lights when you press a button.
- Check the wiring to the unit.
- Verify that the transmitter frequency is properly configured.

Checking AXlink Status

The AXlink LED lights to indicate AXlink power/data status as follows:

- 1 blink per second Indicates power is active and AXlink communication is working.
- 2 blinks per second Indicates the devices specified in the Master program do not match the devices found.
- 3 blinks per second Indicates AXlink communication error.
- Full On Indicates the following conditions:
 - There is no AXlink control or activity, but power is On.
 - The Access program is not loaded.

If the LED is On and not flashing, disconnect the AXlink connector and recheck all AXlink connections. Then, reconnect the AXlink connector to the panel and verify the LED is flashing once per second.

Mounting the AXD-IR+

Installation method A: Use when installing the swivel-mount unit without using the provided mounting bracket. The cable exit is on the back mounting panel (FIG. 8).

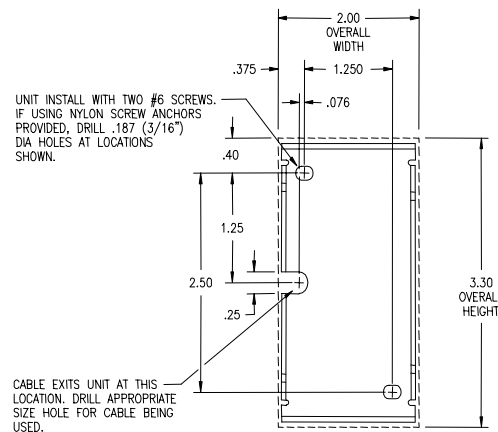

FIG. 8 Installation Method A

Installation method B: Use when installing the swivel-mount unit using the provided mounting bracket (FIG. 9).

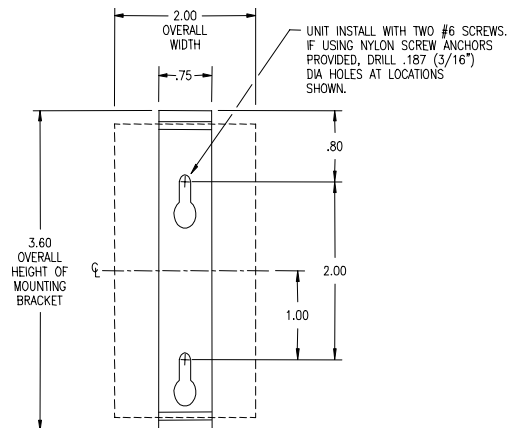

FIG. 9 Installation Method B

- On drywall, use the included wall anchors. Use a 3/16" drill bit.
- On wood, install using the included #6 mounting screws.